



PWS Signs Ltd
 Ravensdale,
 Unit 10 Northlink Business Park,
 Coes Road, Dundalk, Co. Louth,
 A91 WV09
 Tel: (042) 937 5010

PWS Ireland Ltd
 Greenbank Industrial Estate,
 Newry, Co. Down,
 BT34 2QX
 Tel: (028) 3026 4511

✉ info@pwssigns.com
 🖱 www.pwssigns.com

Tiger & Tiger Wand

Cycle Lane Separators

Robust and innovative separator that gives great visibility. Rounded form for enhanced safety. Available with and without Impact Resistant Wand.



Characteristics

- **High visibility day and night.** Due to retroreflective wand.
- **High shock absorption.** Due to flexibility of the material and absence of sharp edges.
- **High mechanical strength.** Due to structure and design of the material.
- **High resistance to weathering.** Due to the material used.
- **Fast and easy to install.** With 3 x anchor bolts.
- **Installation in different positions**
- **Made using Vulcanized Recycled rubber.**

Tiger Base Specifications

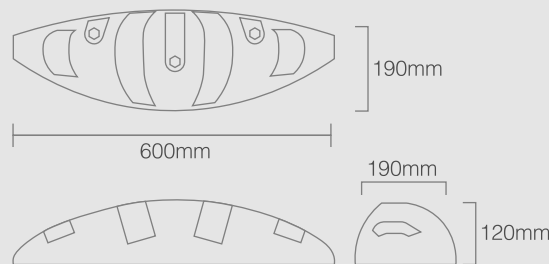

Weight	4.8 kg
Length	600mm
Height	120mm
Width	190mm
Colour	Black

Other colours available.

Made from 100% Recycled Rubber

Rounded edges with no sharp corners.

Positioning options

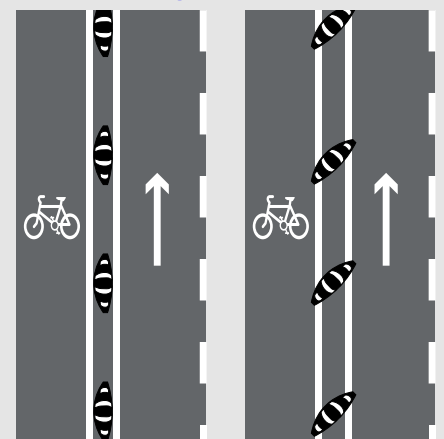

Parallel

Oblique

Tiger Separator



Tiger Wand Variations

The Tiger Wand combines the Tiger separator and FG300 Impact Resistant Bollards for enhanced cycle lane delineation.

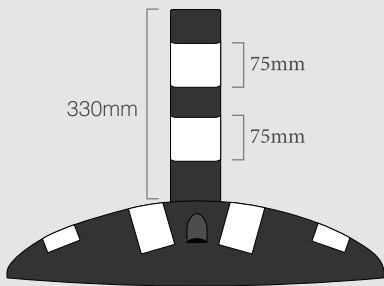

Tiger-Wand 450mm High
Product Ref: Low Level - 2 Hoops

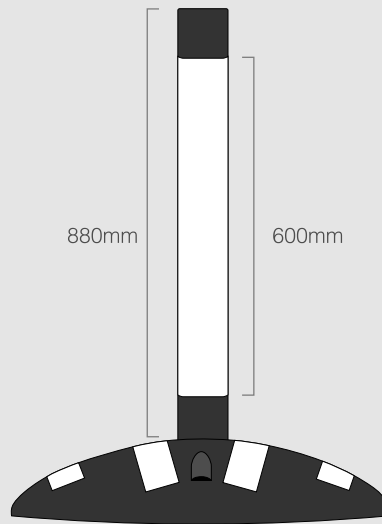

Tiger Wand 1000mm High
Product Ref: High Level/Full Wrap

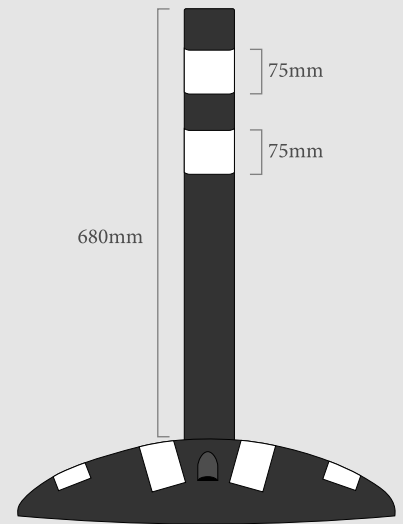

Tiger Wand: 800mm High
Product Ref: High Level 2 Hoops

Tiger Wand Variations



High Level Tiger Wand with 600mm reflective band.



Tiger Wands used in conjunction with Hazard bollards for enhanced cycle lane delineation



Low Level Tiger Wand (450mm Overall Height)



Oblique positioned Tiger Lane separators without Wand